

AMERICAN GOTHIC PLAYHOUSE

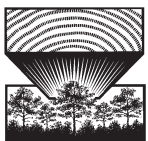

**SOUTHERN
PINE
COUNCIL**

SOUTHERN FOREST PRODUCTS ASSOCIATION
SOUTHEASTERN LUMBER MANUFACTURERS ASSOCIATION

P.O. Box 641700 • KENNER, LA 70064-1700
(504) 443-4464 • FAX (504) 443-6612

www.southernpine.com

American Gothic Playhouse

Copyright ©2005 Southern Forest Products Association. All rights reserved.

Pick a spot and get started with the beautiful American Gothic Playhouse that your kids will love. The design of the playhouse includes 35 square feet of interior space plus a two-foot wide front porch. The overall design along with the elaborate trim and spire can accent any home.

Built of pressure-treated Southern Pine, this playhouse will bring many years of durability and enjoyment to your kids and family, friends, and neighbors. The interior wall framing allows for easy installation of shelves and various playthings. The height of the playhouse even allows for a small loft at the rear. For furnishings, consider lightweight, moveable items so that your children have the freedom to arrange their new setting just how they like it. For the finishing touch, attach a mailbox and street number to give that “moved in” appearance.

OVERALL SIZE

Height: 12’ Width: 5’ Length: 9’

MATERIALS LIST

To build this playhouse, you will need the following quantities of pressure-treated Southern Pine lumber:

NUMBER OF PIECES	MATERIAL	LENGTH	TO MAKE	SERVICE CONDITION
4	2x12	10’	Base frame	Ground Contact
5	2x6	10’	Joists	Above Ground
1	4x4	12’	Corner posts	Ground Contact
3	5/4x6 R.E.D. (Premium Grade)	10’	Porch decking	Ground Contact
7	5/4x6 R.E.D. (Standard Grade)	10’	“stones” around base	Ground Contact
26	1x8	10’	Siding, door trim	Above Ground
10	1x6	10’	Door, verge boards, fascia	Above Ground
2	1x4	10’	Door braces, trim, railing trim	Above Ground
30	1x2	8’	Battens, trim	Above Ground
8	2x2	8’	Spacers at roof, trim at windows	Above Ground
36	2x4	12’	Rafters, wall framing, railings	Above Ground

Pressure-treated Plywood:

2	4x8	3/4”	Floor
4	4x8	1/2”	Roof sheathing

OTHER MATERIALS NEEDED

- 6d, 8d, 10d, 12d hot-dip galvanized or stainless steel nails
(See Fastener Advisory)
- 3 pairs of galvanized hinges
- Water repellent sealer
- 15b. roofing felt
- Shingles
- Door latch
- Joist hangers
- 2 windows
- Black 6-mil polyethylene vegetation barrier
(may use pea gravel in place of plastic barrier)
- Concrete (for setting posts)
- Construction adhesive for pressure-treated wood

TOOLS REQUIRED

- Circular or crosscut saw
- Miter saw
- Hammer
- Drill
- Razor knife
- Square
- Level
- Carpenter’s rule or tape
- Post-hole digger

ADVISORY:

Fastener & Connector Performance for Treated Wood

Metal products in contact with pressure-treated wood must be corrosion resistant. Examples include flashing, termite shields, fasteners (e.g. nails, screws, and bolts), and all connecting hardware (e.g. joist hangers, straps, hinges, post anchors, and truss plates).

The International Residential Code, Section R319.3 states, “Fasteners for pressure-preservative treated wood shall be of hot-dipped galvanized steel, stainless steel, silicon bronze or copper. **Exception:** One-half inch (12.7mm) diameter or greater steel bolts.”

Traditionally, the treated wood industry has recommended hot-dip galvanized or stainless steel fasteners and connectors for wood products treated with Chromated Copper Arsenate (CCA). Hot-dip galvanized or stainless steel fasteners and connectors continue to be recommended for use with alternative wood preservatives (e.g. Alkaline Copper Quat – ACQ – and Copper Azole), but additional clarification is needed to ensure adequate corrosion protection.

Type 304 or 316 stainless steel is recommended for maximum corrosion resistance in more severe exterior applications, such as swimming pools and salt-water exposure. Furthermore, stainless steel fasteners are generally required below grade for permanent wood foundations.

Hot-dip galvanized fasteners and connectors are generally acceptable for above grade applications. Hot-dip galvanized *fasteners* should meet ASTM A153 (with 2 ounces of zinc coating per square foot minimum for marine use) and hot-dip galvanized *connectors* should meet ASTM A653, Class G185 sheet with 1.85 ounces of zinc coating per square foot minimum. Fasteners and connectors used together should be of the same type (e.g. hot-dip nails with hot-dip joist hangers).

Do not use standard carbon-steel or aluminum products in direct contact with pressure-treated wood. Spacer materials or other physical barriers are recommended to prevent direct contact. In addition, electroplated galvanized metal products generally have a thinner layer of protection compared to hot-dip galvanized and are typically not accepted by the building codes for use in exterior applications.

Fasteners and connectors coated with proprietary anti-corrosion technologies (other than stainless steel or hot-dip galvanized) are also available for use with treated wood. Consult individual hardware manufacturers for specifics regarding the performance of their products with treated wood.

CONSTRUCTION STEPS

NOTE: Refer to the Assembly Diagram as needed.

1. Determine exact location of playhouse. Cut 6-mil polyethylene vegetation barrier to a length of 5'-5" x 10'-10". Lay barrier on ground area where playhouse will be located.
2. From the 10' 2x12s, cut two frame ends 5'. Attach the frame ends to the 10' frame sides, using 10d nails.
3. Cut four 2x6 flooring joists to a length of 4'-9" each. Position flooring joists 16" o.c. (on center) and nail to frame sides using 10d nails.
4. From a 2x12, cut a 4'-9" crosspiece. On the porch end of the flooring frame, position and nail (using 10d nails) the crosspiece 30" from the outside of the frame end.
5. Cut two 2x6 flooring joists. Evenly space the joists between the frame sides and nail to crosspiece and frame ends with 10d nails. Be sure top of joists are flush with top of frame.
6. Cut 6" R.E.D. blocks for perimeter of 2x12 framing base. Round off ends to give brick-like appearance. Attach blocks to base using 8d nails.
7. With post-hole digger, dig 4 holes approximately 2'-6" in depth. Cut four 3' 4x4 posts and set in holes with concrete at the inside corners of the playhouse frame. (The porch frame does not require 4x4 posts). Be sure tops of 4x4s are flush with top of the frame. Check for level and square. Toe-nail posts to frame using 12d nails.
8. Using 3/4" treated plywood, cut two flooring pieces, 4'x5' and 2'-8"x5'. NOTE: You can adjust measurements slightly to ensure flooring seam is lined up with 2x6 flooring joist. Nail plywood flooring to frame using 8d nails.
9. Cut R.E.D. boards to fit 30"x60" porch frame. Fasten deck boards using 8d nails.
10. Fabricate 53" high side and rear stud walls using 2x4s. Space studs 20" on center for rear wall. Nail studs to 2x4 top and bottom members using 10d nails. Cut and attach horizontal 2x4 framing braces between each 2x4 stud.
Fabricate front stud wall. From a 2x4, cut two 5' door frame pieces; nail to 2x4 horizontal braces using 10d nails. Refer to plan. Attach two 2x4 supports (cut supports at 45° angle using miter saw) in top corners of door frame. Attach and nail upper 2x4 member to the 2x4 studs and end rafters.
11. Connect wall frame sections with 2x4 top plates. Use 80" lengths at the sides and a 60" length on front; attach with 10d nails. Side top plates become rafter supports. Wall framing is complete; check for square.
12. Cut 2x4 rafters from 12' lengths. Refer to plan for roof slope and notch detail.
13. Cut five 1x4 collar beam supports for the 1x6 ridge board. Notch one end to receive 2x4 end rafters. Toe-nail into place using 12d nails. Attach 7'-6" 1x6 ridge board using 8d nails and construction adhesive.
14. Install roof rafters 20" on center. Nail to ridge board using 10d nails; toe-nail to rafter support using 12d nails. Framing is complete.
15. Enclose wall framing using treated 1x8 boards and 1x2 battens. NOTE: Interior can be finished with 3/8" treated plywood.
16. Construct and install door. Refer to plan for details.
17. On each side wall, build a window frame to fit 24"x24" windows. Cut and attach 1/2" trim around window frame. Refer to plan for window and window box details.
18. Install deck railing. Refer to plan for design and construction details.
19. Cut four 2x4 spacers the same length as the rafters. Nail to rafters on front and rear sides of playhouse using 10d nails. Cut blocking piece for spire and nail below edge of 1x6 ridge board on front side.
20. Cover roof framing with 1/2" treated plywood; use 6d nails and construction adhesive. Add a layer of roofing felt. Install shingles with roofing nails.
21. Attach spire to blocking using 10d nails. Be sure nail holes are predrilled. Refer to plan for design and construction of spire.
22. Complete trim work. On playhouse sides, attach 1x6 fascia boards flush with edge of rafters. On front and rear sides, attach 1x6 fascia boards to 2x4 spacer; also attach 1x6 verge board and picture molding. Refer to plan for verge board design. Install all trim using 8d nails and construction adhesive.
23. Now that construction is complete, apply a coat of water-repellent sealer or paint to the floor and all exterior wood surfaces.



www.southernpine.com

These plans and the information contained herein will help you achieve the best possible results in working with Southern Pine lumber products. The conditions under which lumber is used in construction vary widely, as does the quality of workmanship. Since neither the Southern Pine Council nor its members control the method of use or the quality of workmanship in structures built with lumber, they do not warrant lumber performance or design in completed structures.

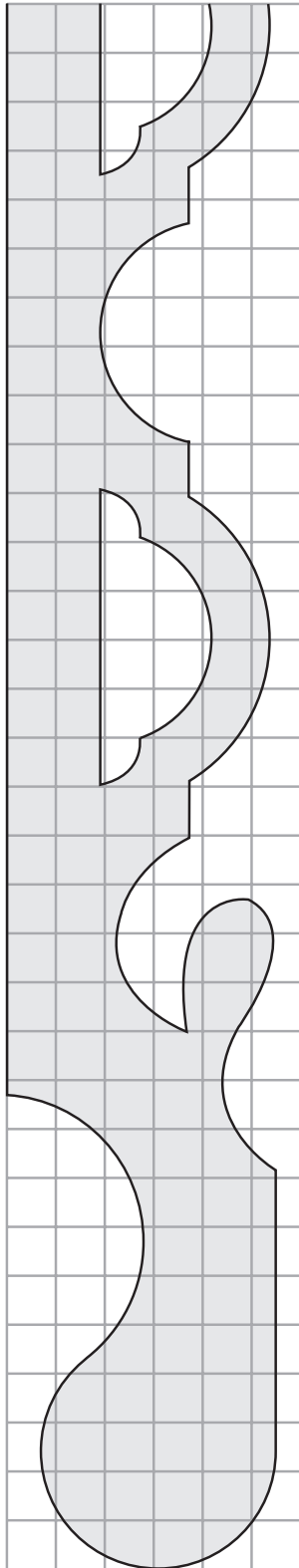

VERGE BOARD

1 SQUARE = 1"
(CUT FROM 1x6)

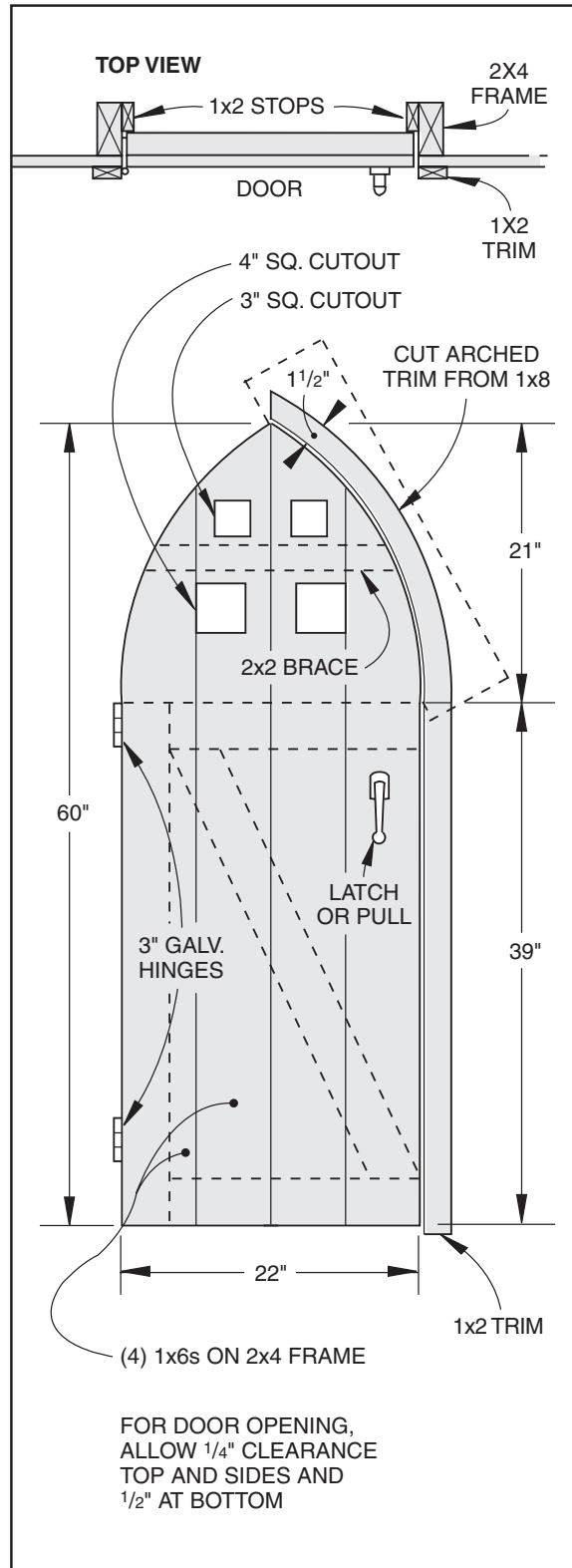

DOOR DETAIL

SPIRE DETAIL

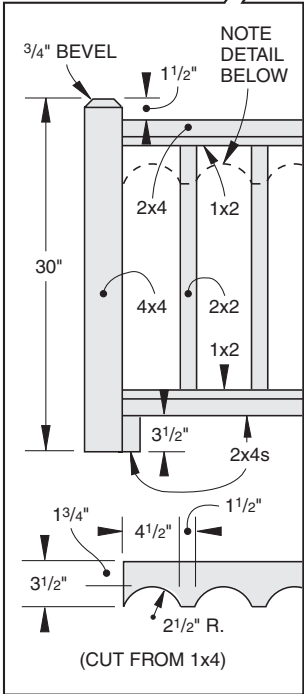
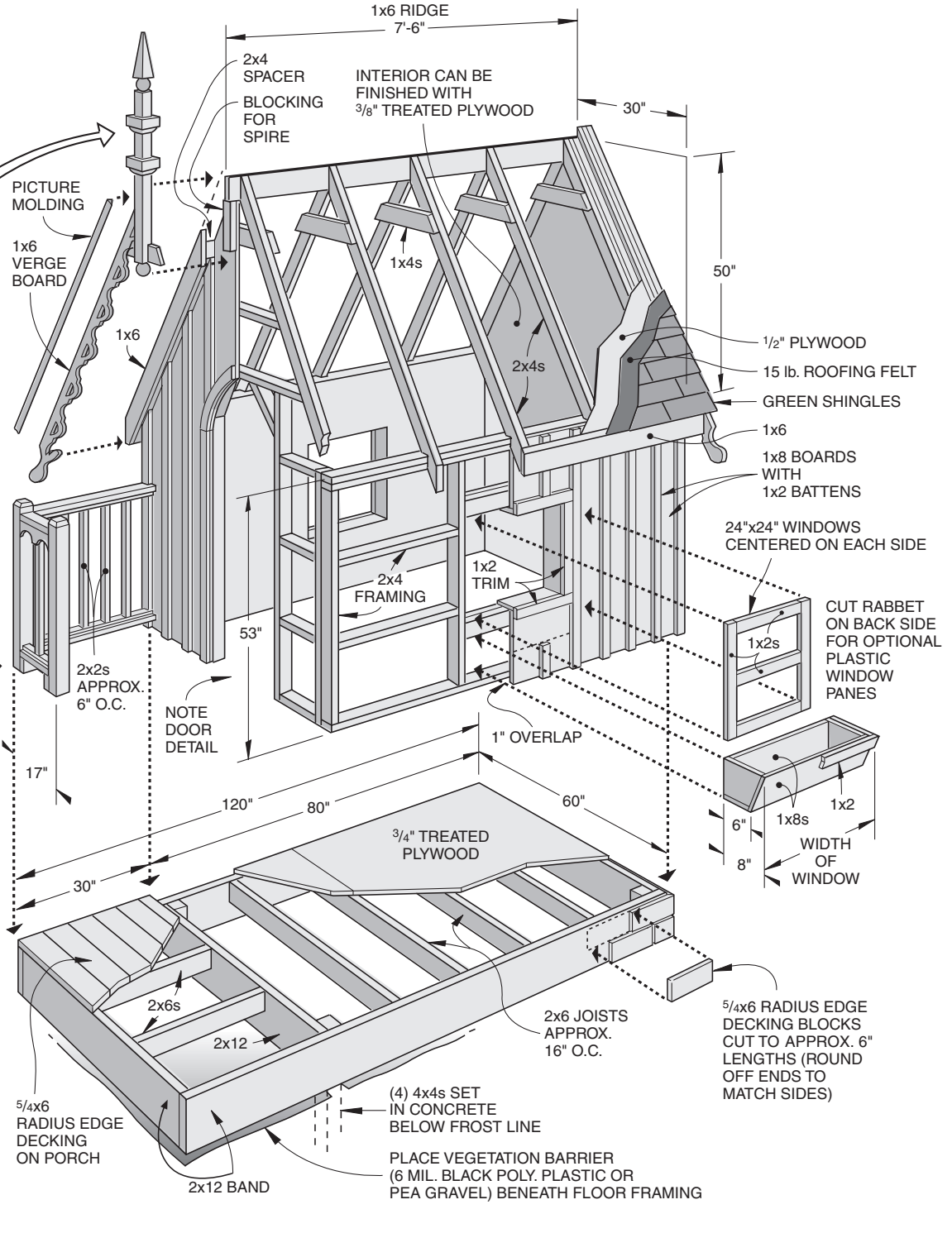
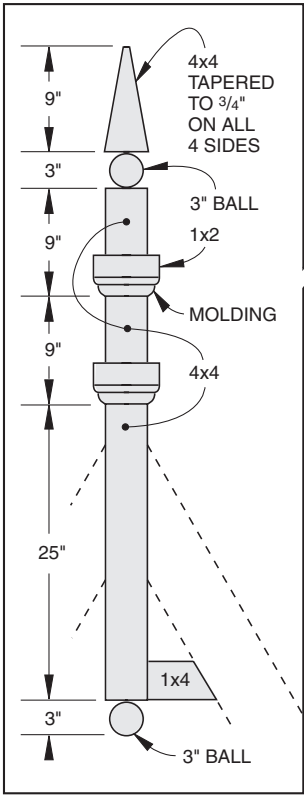

DECK RAILING DETAIL